

A

ALLE LUSSO SHADES

DELIVERS SILENCE

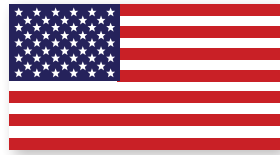

SUPER
Sileo

Sileo

MOTORS BY

 GAPOSA



100%
GENUINE
ITALIAN



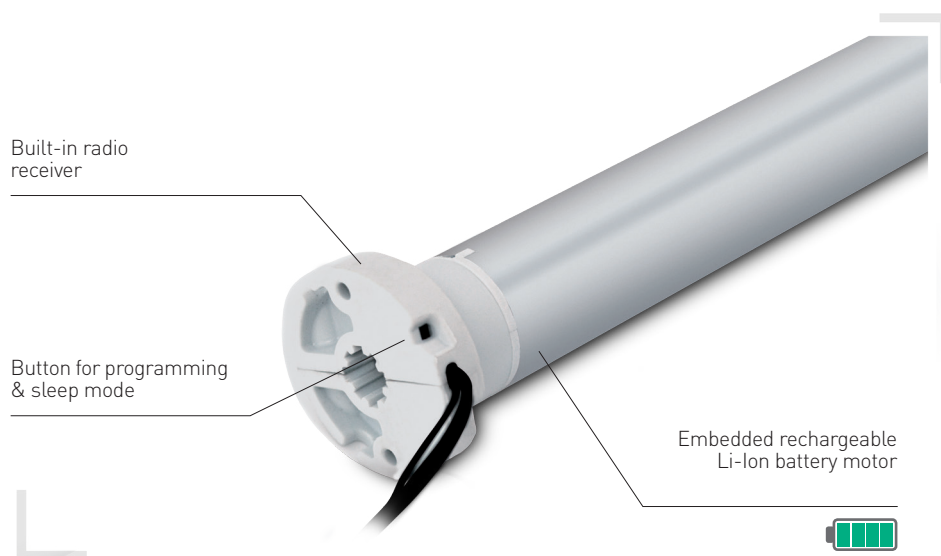

MAIN FEATURES

Models	XSDC3EZ030B	XSDC3EZ226B
Torque	1.1 Nm	2 Nm
Speed	30 rpm	26 rpm
Power	15 W	18 W
Amps	1.40 A	1.60 A
Limit switch	Electronic	Electronic
Max turns	70	70

TECHNICAL DATA

Voltage	12 VDC
Duty rating	45 sec ON / 1 min OFF
Radio frequency	434.15 MHz
Protection	IP30
Working temperature	14°F / 104°F
Insulation class	III

DIMENSIONS in

Model	A
XSDC3EZ030B	21.06
XSDC3EZ226B	21.65

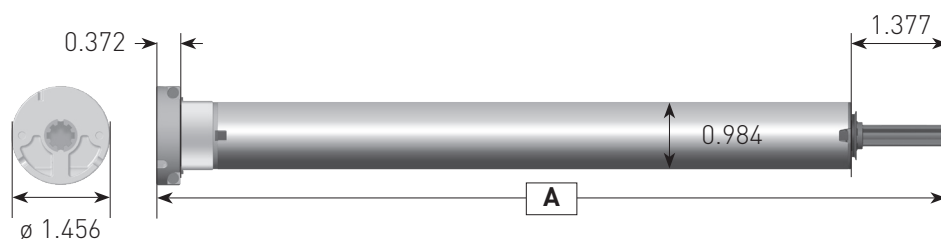

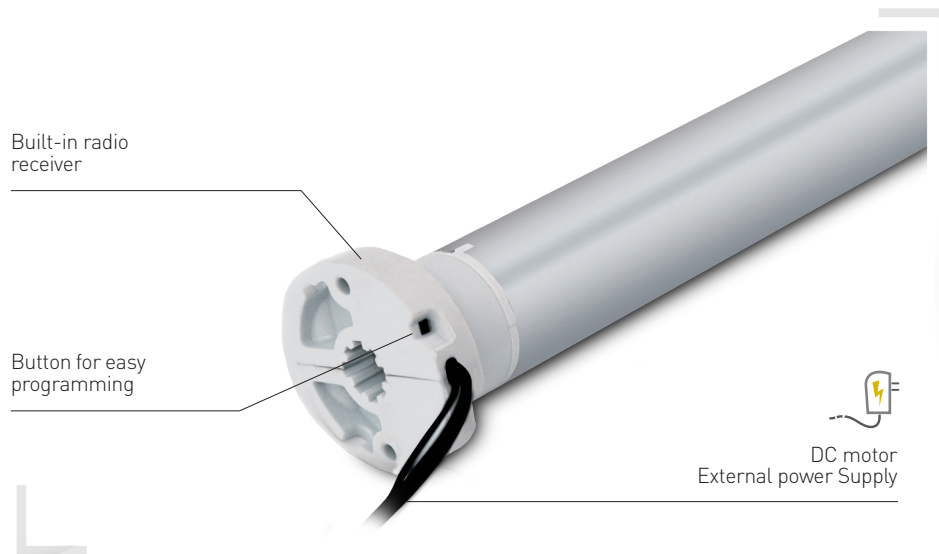

MAIN FEATURES

Models	XSDC3EZ128	XSDC3EZ228
Torque	1.5 Nm	2 Nm
Speed	28 rpm	28 rpm
Power	22 W	25 W
Amps	0.90 A	1.10 A
Limit switch	Electronic	Electronic
Max turns	35	35

TECHNICAL DATA

Voltage	24 VDC
Duty rating	45 sec ON / 1 min OFF
Radio frequency	434.15 MHz
Protection	IP30
Working temperature	14°F / 104°F
Insulation class	III

DIMENSIONS in

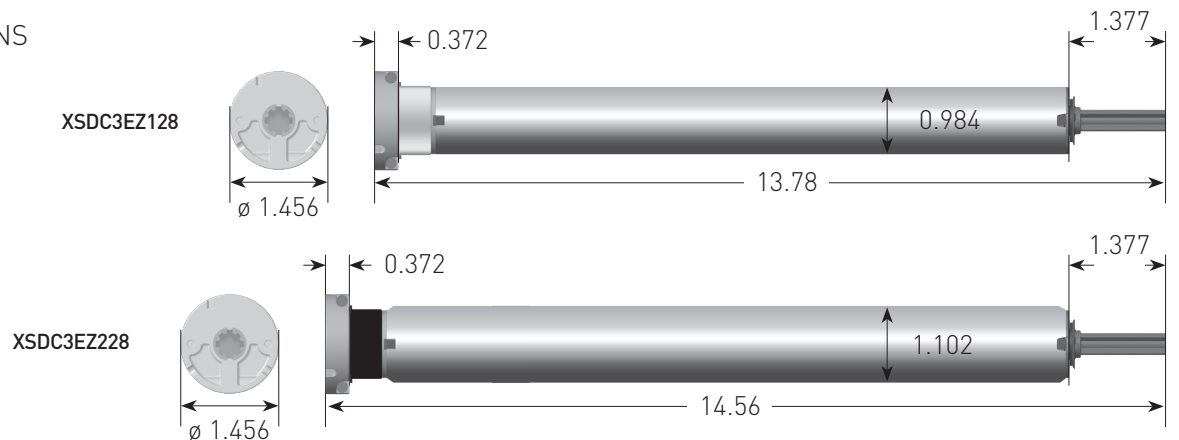

Sileo SUPER XS 50 DC 24V



DC motor,
External power supply

Built-in radio
receiver

- 6 pins connector:
2 for power
4 for control (dry contacts)
- Integrated antenna

2 setting buttons
+ 2 LEDs for easy
setting and a quick
troubleshooting

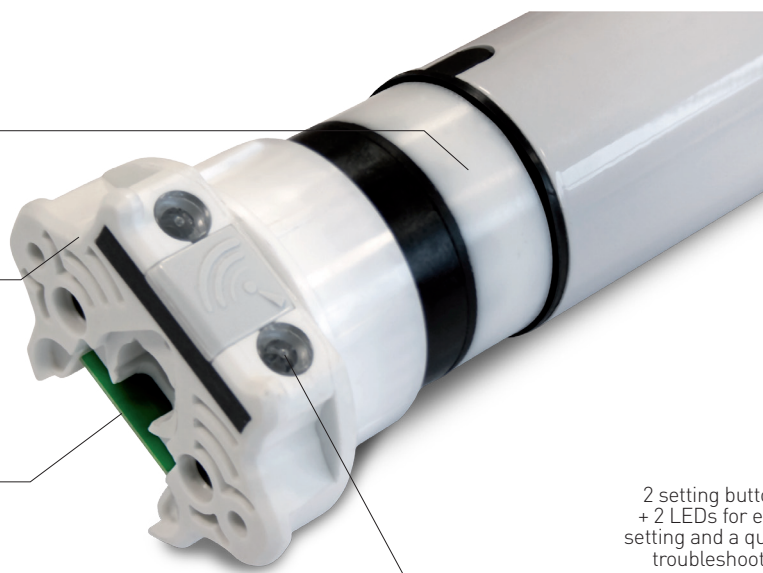

MAIN FEATURES

Models	XSDC5EZ428
Torque	4 Nm
Speed	28 rpm
Power	46 W
Amps	2 A
Limit switch	Electronic
Max turns	55

TECHNICAL DATA

Voltage	24 VDC
Duty rating	45 sec ON / 1 min OFF
Radio frequency	434.15 MHz
Protection	IP30
Working temperature	14°F / 104°F
Insulation class	III

DIMENSIONS in

Model	A
XSDC5EZ428	20.19

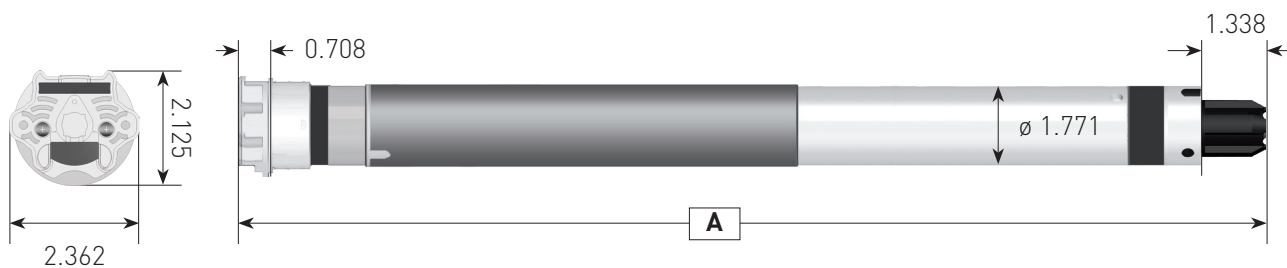

ACCESSORIES

- ▶ BC312.EUR
Li_On battery charger

Motors
XSDC3EZ228B
XSDC3EZ030B



- ▶ TRASDC3.120
Switching power supply 2 Amps

Motors
XSDC3EZ128
XSDC3EZ228



- ▶ TRAS.120
Switching power supply 2,5 Amps

Motors
XSDC5EZ815
XSDC5EZ428



- ▶ FLAX14W007.L1 (6.102 in)
FLAX14W007.L2 (48.03 in)
FLAX14W007.L3 (96.06 in)
Power cord extension with plugs (for DC battery motors)



- ▶ FLAX13W070
Plug-in power cable for XSC50
motor without dry contacts



- ▶ FLAX13W065
Power cable for XSC50
motor with dry contacts



POWER DISTRIBUTION PANELS 24V DC

ARM4

Power supply for 4 XSDC30 motors

Technical details

Input voltage	100-240Vac 50/60Hz
Amps	2.1 A
Output	4.5 A, 100 W
Motor connections	4
Working temperature	-10°F /+158°F
Dimensions	5.236 x 8.188 x 3.149 in



ARM5

Power supply for 5 XSDC50 motors with dry contact input for each motor and for group control

Technical details

Input voltage	100-240Vac 50/60Hz
Amps	3.0 A
Output	10 A, 250 W
Motor connections	5 (DC power) + 5 (Dry contact)
Working temperature	-10°F /+158°F
Protection fuse	4.0 A
Dimensions	12.008 x 8.268 x 4.724 in



XS4EZ

Electronic encoded type
with built-in radio
receiver

SMART
FEATURES

- ▶ Easy limit setting via radio
- ▶ Secure 434.15 MHz radio transmission
- ▶ Easy set up of group controls
- ▶ Up and down directions synchronized while setting the limits
- ▶ Noiseless soft brake

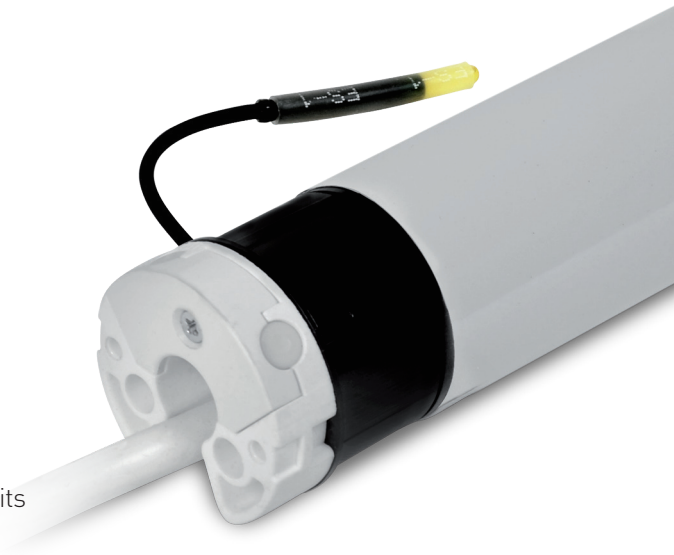

MAIN
FEATURES

Models	XS4EZ334	XS4EZ624
Torque	3 Nm	6 Nm
Speed	34 rpm	24 rpm
Rated current	0.90 A	1.20 A
Limit switch max turns	160	160

TECHNICAL
DATA

Power Supply	120 VAC / 60 Hz
Working temperature	14°F / 104°F
Duty rating	45 sec ON / 1 min OFF
Radio frequency (type)	434.15 MHz
Protection	IP44

Standard cable length	8 ft
	4x18 AWG White - Neutral
	4x18 AWG Green - Ground
	4x18 AWG Black

DIMENSIONS
in

Model	A	Model	A
XS4EZ334	23.66	XS4EZ624	25.03

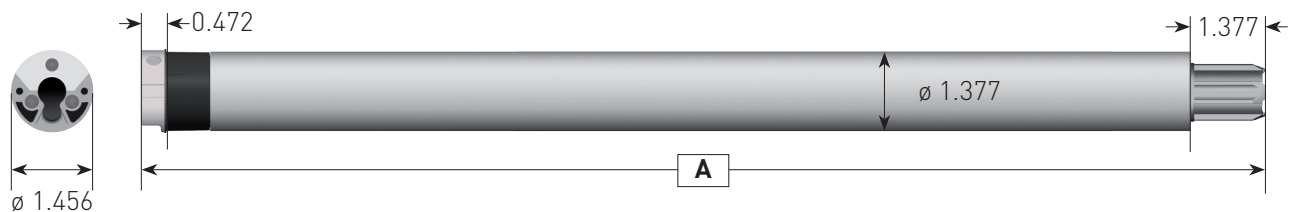

XS5EZ

Electronic encoded type
with built-in radio
receiver

SMART FEATURES

- ▶ Easy limit setting via radio
- ▶ Secure 434.15 MHz radio transmission
- ▶ Easy set up of group controls
- ▶ Up and down directions synchronized while setting the limits
- ▶ Wireless connection with climatic sensors
- ▶ Noiseless soft brake
- ▶ Plug-in cable

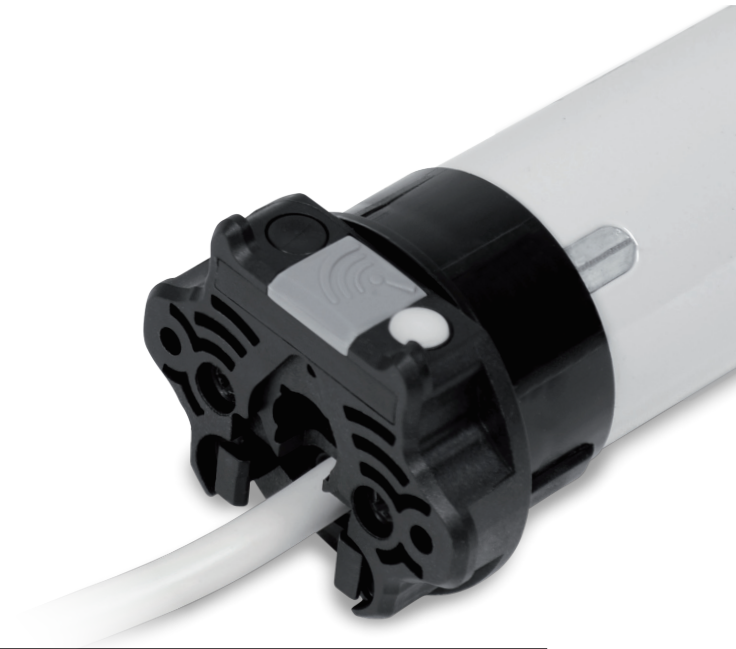

MAIN FEATURES

Models	XS5EZ525
Torque	5 Nm
Speed	25 rpm
Rated current	0.9 A
Limit switch max turns	80

TECHNICAL DATA

Power Supply	120 VAC / 60 Hz
Working temperature	14°F / 104°F
Duty rating	45 sec ON / 1 min OFF
Radio frequency	434.15 MHz
Protection	IP44

Standard cable length	8 ft
	4x18 AWG White - Neutral
	4x18 AWG Green - Ground
	4x18 AWG Black

DIMENSIONS in

Model	A
XS5EZ525	21.29

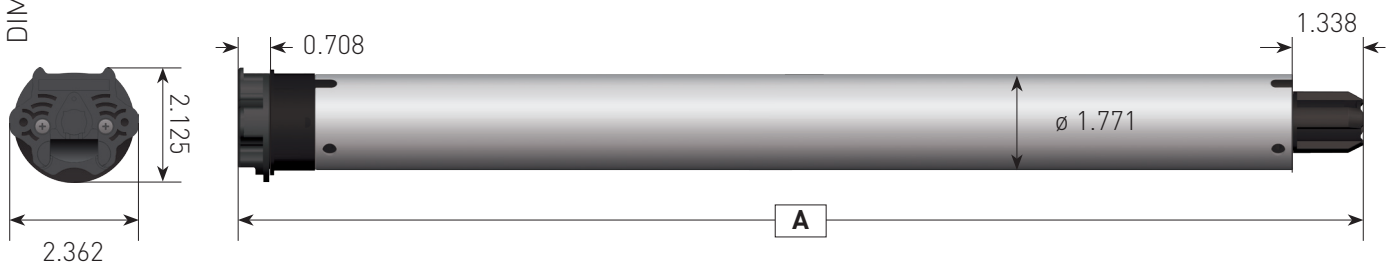

XQ5EZ

Electronic encoded type
with built-in radio
receiver

SMART
FEATURES

- ▶ Easy limit setting via radio
- ▶ Secure 434.15 MHz radio transmission
- ▶ Easy set up of group controls
- ▶ Up and down directions synchronized while setting the limits
- ▶ Wireless connection with climatic sensors
- ▶ Noiseless soft brake
- ▶ Plug-in cable





MAIN
FEATURES

Models	XQ4EZ634	XQ4EZ934
Torque	6 Nm	9 Nm
Speed	34 rpm	34 rpm
Rated current	0.90 A	1.10 A
Limit switch max turns	80	80

TECHNICAL
DATA

Power Supply	120 VAC / 60 Hz
Working temperature	14°F / 104°F
Duty rating	45 sec ON / 1 min OFF
Radio frequency	434.15 MHz
Protection	IP44

Standard cable length	8 ft
	 4x18 AWG White - Neutral  4x18 AWG Green - Ground  4x18 AWG Black

DIMENSIONS
in

Model	A	Model	A
XQ5EZ634	21.37	XQ5EZ934	22.59

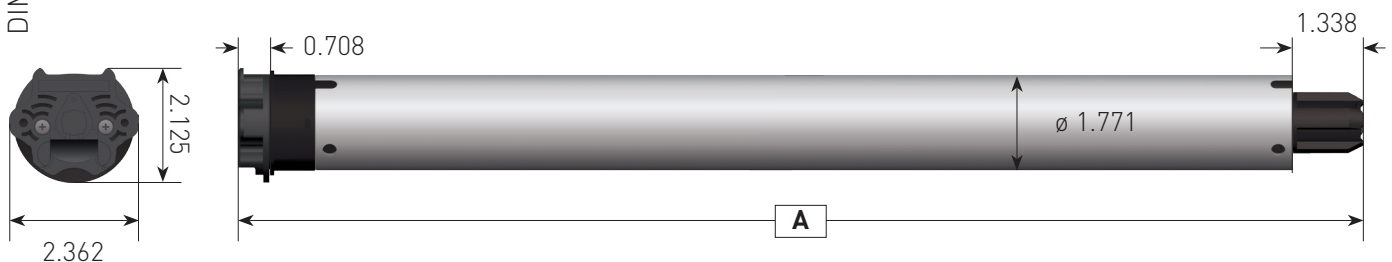

XQ5EZ Electronic encoded type with built-in radio receiver

SMART FEATURES

- Downwards sensitive obstacle detection
- 3 attempts to identify the physical obstacle before stopping
- Smart reaction to gusts of wind: stop/reverse and downwards again
- Overload protection upwards
- Soft touch and slight release at the up limit position
- Continuous fabric length compensation
- 3 setting modes: automatic, semi-automatic, manual
- Self-learning limit positions when set in automatic mode
- Available in **XS** type for the quietest operation

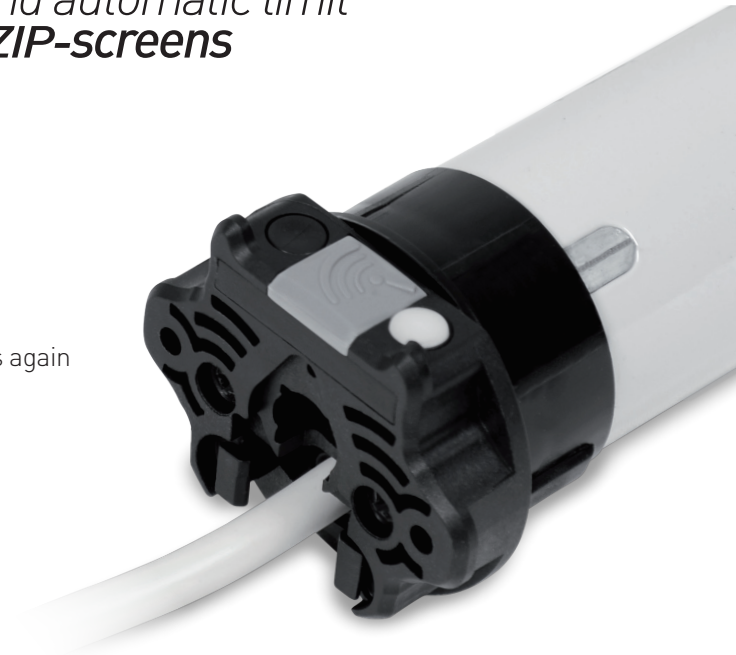

MAIN FEATURES

Models	XQ5EZ2521	XS5EZ4016
Torque	25 Nm	40 Nm
Speed	21 rpm	16 rpm
Rated current	1.60 A	1.80 A
Limit switch max turns	80	80

TECHNICAL DATA

Power Supply	120 VAC / 60 Hz
Working temperature	14°F / 104°F
Duty rating	45 sec ON / 1 min OFF
Radio frequency	434.15 MHz
Protection	IP44

Standard cable length	8 ft
	4x18 AWG White - Neutral
	4x18 AWG Green - Ground
	4x18 AWG Black

DIMENSIONS in

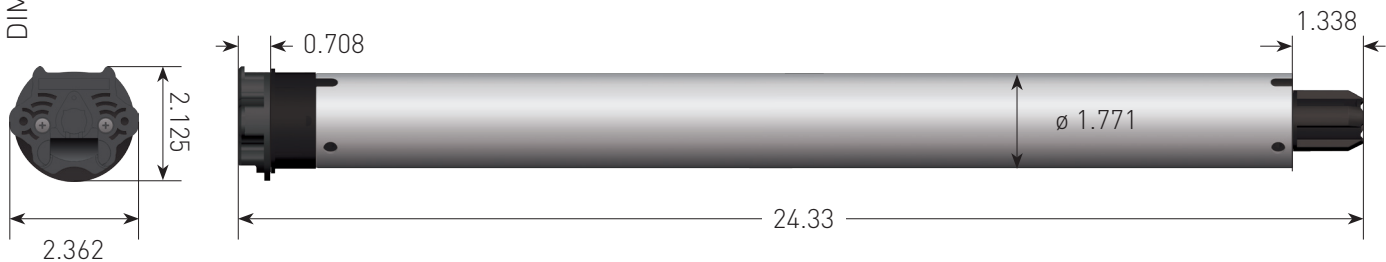

XQ50 SHSM *Super high speed motor*

XQ5EZ Electronic encoded type with built-in radio receiver

SMART FEATURES

- ▶ Easy limit setting via radio
- ▶ Secure 434.15 MHz radio transmission
- ▶ Easy set up of group controls
- ▶ Up and down directions synchronized while setting the limits
- ▶ Wireless connection with climatic sensors
- ▶ Noiseless soft brake
- ▶ Plug-in cable



MAIN FEATURES

Models	XQ5EZ790 SHSM
Torque	7 Nm
Speed	90 rpm
Rated current	1.80 A
Limit switch max turns	80

TECHNICAL DATA

Power Supply	120 VAC / 60 Hz
Working temperature	14°F / 104°F
Duty rating	45 sec ON / 1 min OFF
Radio frequency	434.15 MHz
Protection	IP44

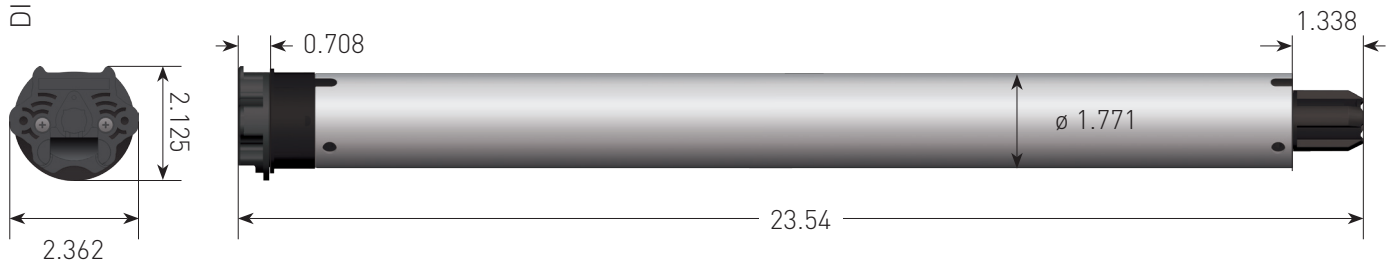

Standard cable length	8 ft
	4x18 AWG White - Neutral
	4x18 AWG Green - Ground
	4x18 AWG Black

DIMENSIONS mm





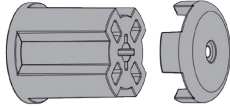

ADAPTERS







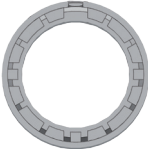

■ DC30 range motors

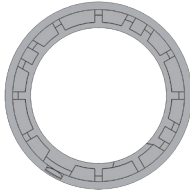
Drive wheel	Crown adapter			
		Code: AX3.01P138 Tube: Round tube 1" - 1/2 / 38 mm		
				AXRRF3 ADAPTOR FROM XSDC30 TO XS/XQ40 MOTOR CROWN

■ 40 range motors

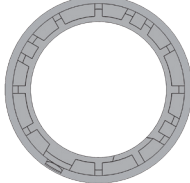
Drive wheel	Crown adapter		Drive wheel	Crown adapter	
		Code: AX4.01P061 Tube: Round for 2" / 50mm			Code: AX4.01P078 Tube: Round for 48mm
		Code: AXRRF4 ADAPTOR FROM XQ40 TO XQ50 MOTOR CROWN			

■ 50 range motors

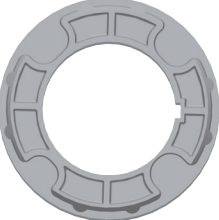
Drive wheel	Crown adapter		Drive wheel	Crown adapter	
		Code: AXR50 Tube: Round 2" / 50 mm			Code: AX06.EC Tube: Round 2" - 1/2 / 73 mm
		Code: AX5.01P079 Tube: Round 2" / 50 mm with grooves			Code: AX5.01P205 Tube: Round 3" - 1/4 / 83 mm
		Code: AXGS78M Tube: 2.75" with grooves			

TRANSMITTERS



The *Emitto Slim line* is a range of handheld and wall mount transmitters. *Emitto Slim line* is easy to pair and to use. With the simple touch of a button one or more channels can be selected.



QCTZ01H

Portable - 1 Channel



QCTZ02H

Portable - PRESET / ALL

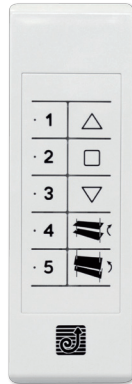

QCTZ04H

Portable - TILTING



QCTZ01D

Wall-mounted Dekora - 1 Channel



QCTZ02D

Wall-mounted Dekora- PRESET / ALL

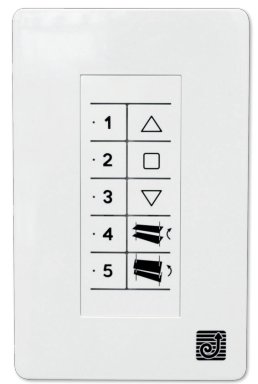

QCTZ04D

Wall-mounted Dekora - TILTING



QCTZ01W

Wall-mounted - 1 Channel



QCTZ02W

Wall-mounted - PRESET / ALL

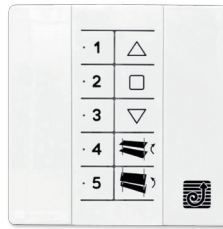

QCTZ04W

Wall-mounted- TILTING

Technical details

Channels	1 to 5
Frequency	434.15 MHz
Power supply	3V mod. CR2032
Battery life	2 years
Radiated power	0,150 mW
Protection rate	IP40
Coverage (int/extl)	65 / 600 ft
Encoding	RC Gaposia
Working temperature	14°F / 104°F



A 16 channel remote with LCD display. Smart16 is the most sophisticated remote of all the range with a unique easy set up procedure and the most user friendly operation found in the market. A simple touch will select what to control between individual channels and groups.

Features:

- 16 channels for individual control
- Possibility to create and control 8 custom groups in addition to all channels
- Hide the unused channels
- Magnetic wall mount bracket



Technical details

Channels	16
Frequency	434,15 MHz
Power supply	3V - CR2450
Battery life	2 years
Radiated power	0,150 mW
Protection rate	IP30
Coverage (int/extl)	65 / 600 ft
Encoding	RC Gaposia
Working temperature	14°F / 104°F
Dimensions	1.85x5,90x0,47 in
Weight	0.14 lb



Sleek, longer ergonomic handheld remote combining elegant design and durability. A body made from an ionomer resin resistant to drops with a "Soft touch" feel is available in translucent, white, and black.

QCTX01KT

QCTX03KW

QCTX04KB



Technical details

Channels	1-5
Frequency	434,15 MHz
Power supply	3V mod. CR2430
Battery life	2 year
Radiated power	0,150 mW
Protection rate	IP40
Coverage (int/extl)	65 / 600 ft
Encoding	RC Gaposia
Working temperature	14°F / 104°F
Dimensions	1,61x7,20x0,39 in
Weight	0.12 lb

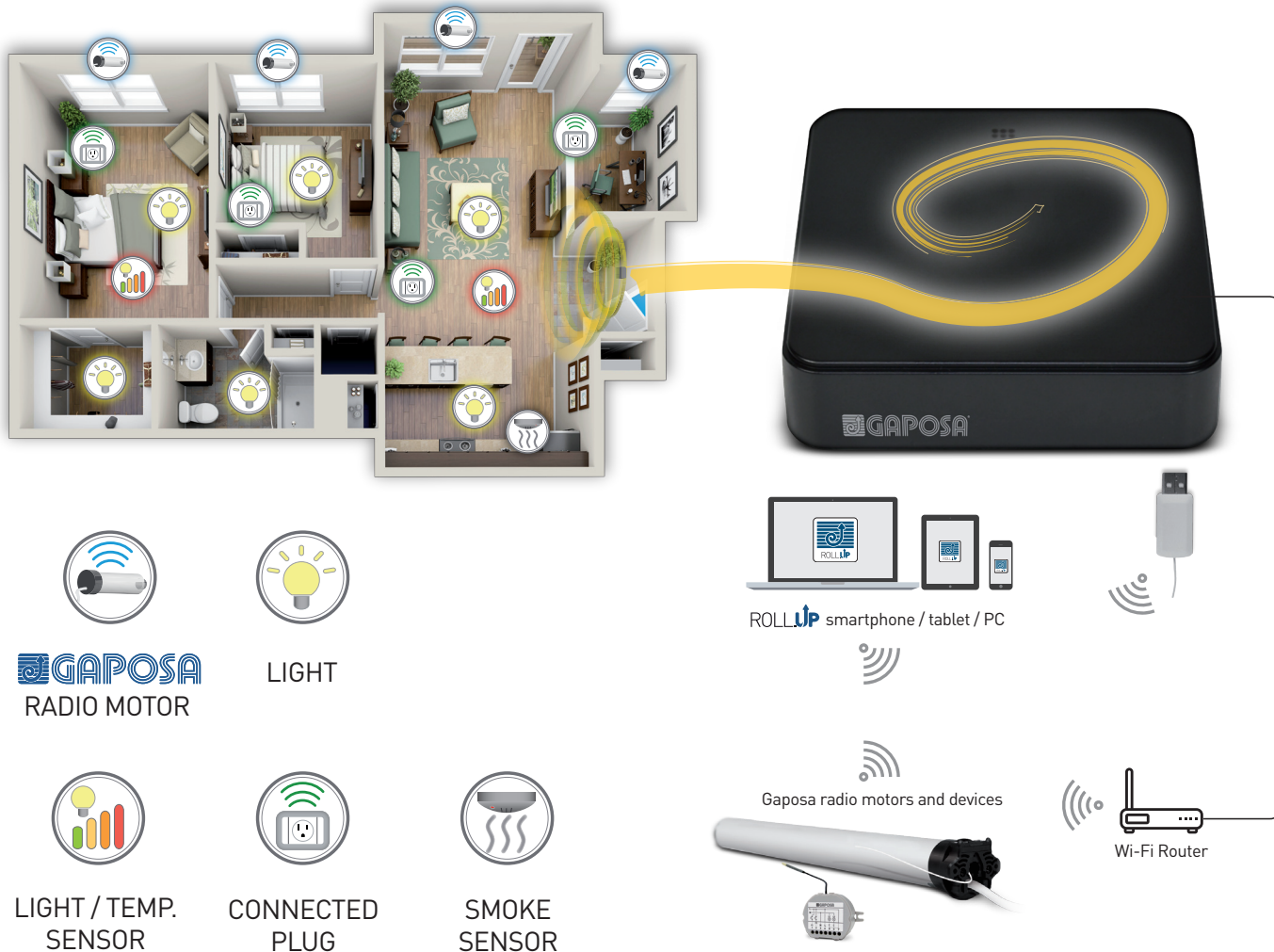

Features

- Information securely stored locally
- 3 types of scenarios for an ultra simple set up
- Simple and fast installation
- Vacation scenario with random feature
- Designed for Smartphone, tablets or PC
- No limits to the number of scenes and connected devices
- Autonomous server does not use Cloud technology
- Free remote access without any subscription
- Amazon's Alexa compatible



Gaposa 3rd party integration via dry contacts with: Lutron, Savant, Control4, Crestron



QCTZ3SDU
1 channel



QCTZ36SDU
6 channels

Panels with integrated transmitter enables to interface a radio motors with a home automation system. In this way, the home automation system will control the radio motor(s) through the UP/STOP/DOWN signals.

Power supply	120V~ - 60 Hz (±10%)
Frequency	434.15 MHz
Fuse	315 mA
Protection rate	IP44
Working temp.	14... 140 °F

RS232 integration + WiFi coming soon



linkIT

Models

- linkIT-US8 8 channels (434.15 MHz)
- linkIT-US16 16 channels (434.15 MHz)

Control

- 8-16 blinds or groups per device
- Up - Down - Stop
- Intermediate position
- Tilting

Applications

- Control4 driver
- Crestron via RS232
- Lutron via RS232

Integrations

- RS232 via RJ45
- TC/IP/Wi-Fi (Q1, 2020)

Hardware

- Very small dimensions (80x55x24 mm)
- Visible feedback
- Exterior antenna for increased range
- LED for power
- Upgradable
- Interconnectable
- 5V power input

PROGRAMMING QUICK GUIDE

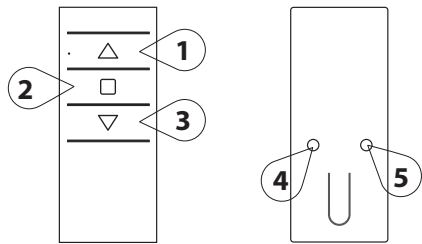

The buttons shown on the left are used to program the transmitters and specific channels. The programming button's (buttons 4 and 5) locations can be placed differently depending on the transmitter model. Shown in this guide is the Emitto Slim line transmitter.

- UP (1)** the motor lifts the rolling shade/awning up
- STOP (2)** the rolling shade/awning stops
- DOWN (3)** the rolling shade/awning goes down
- SYNC (4)** program the transmitter
- LIMIT (5)** set limits

CONNECT POWER TO THE MOTOR

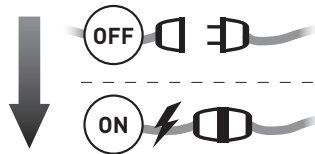

PROGRAMMING A TRANSMITTER (Sec. 1)

- 1** Press and hold **SYNC** button on the back of transmitter or the white button on the head of the motor until the motor starts moving
- 2** Check the motor rotation (**UP** or **DOWN**) then release the **SYNC** button or the white button (the motor now stops)
- 3** Within 5 seconds, press the corresponding button (**UP** if the motor turns upwards or **DOWN** if the motor turns downwards.) This will set the direction of the motor. If the incorrect button is pressed, the controls will be reversed. To fix, see Sec. 3.

Transmitter is now programmed

ADDING A NEW TRANSMITTER (Sec. 2)

- 1** Press and hold the **SYNC** button on the back of a transmitter **ALREADY** paired until the motor starts moving in one direction
- 2** Check the motor rotation (**UP** or **DOWN**) then release the **SYNC** button (the motor now stops)
- 3** Within 5 seconds, press the corresponding button (**UP** if the motor turns upwards or **DOWN** if the motor turns downwards) on the **NEW** transmitter being added. This will set the direction of the motor. If the incorrect button is pressed, the controls will be reversed. To fix, see Sec. 3.

Additional transmitter is now added

CHECKING / CHANGING DIRECTION (Sec. 3)

To check the direction, press the UP or DOWN button. The motor will go UP or DOWN accordingly, if the direction needs to be changed:

- 1** Press and hold the SYNC button on the back of transmitter until the motor starts moving
- 2** Press the STOP button; the motor makes a brief jog. The direction of the motor has been reversed

IMPORTANT: the change of direction of procedure must be performed before initiating the limit setting procedure, otherwise limits must be reset

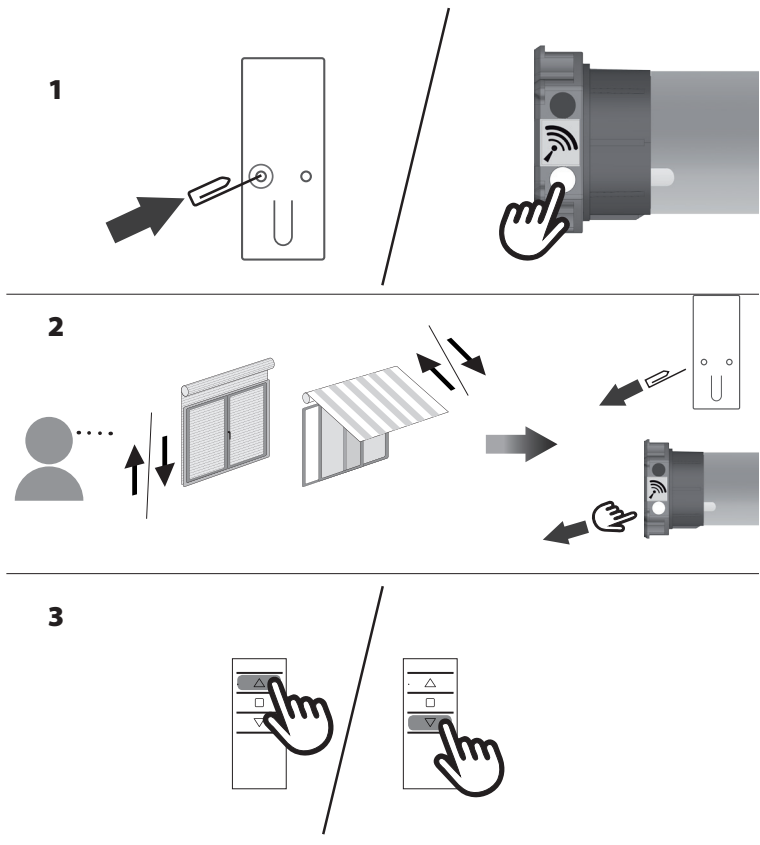

SETTING THE LIMITS (Sec. 4) IT IS MANDATORY TO SET THE "UP" LIMIT FIRST EVERY TIME

Run the motor to an intermediate position inbetween the two desired limits. The motor needs to move in the direction of the limit in order for the limit to be properly set.

- 1 Press and hold the LIMIT button on the back of transmitter until the motor makes a brief jog

Note: during "limit setting mode" the operations are in "deadman control" (The UP and DOWN buttons must be held down in order to move the motor.)

- 2 Press and hold the UP button and run the motor to the desired UP limit position.
- 3 Press the STOP button to set the UP limit position. The motor makes a brief jog to confirm.
- 4 Press and hold the DOWN button and run the motor to the desired DOWN limit position
- 5 Press the STOP button to set the DOWN limit position. The motor makes a brief jog to confirm.

Note: Accurate limit setting can be performed by pressing the LIMIT button a second time: the motor will then reduce its output speed, moving slowly in steps towards the desired limit. Always press the STOP button to set the limit position.

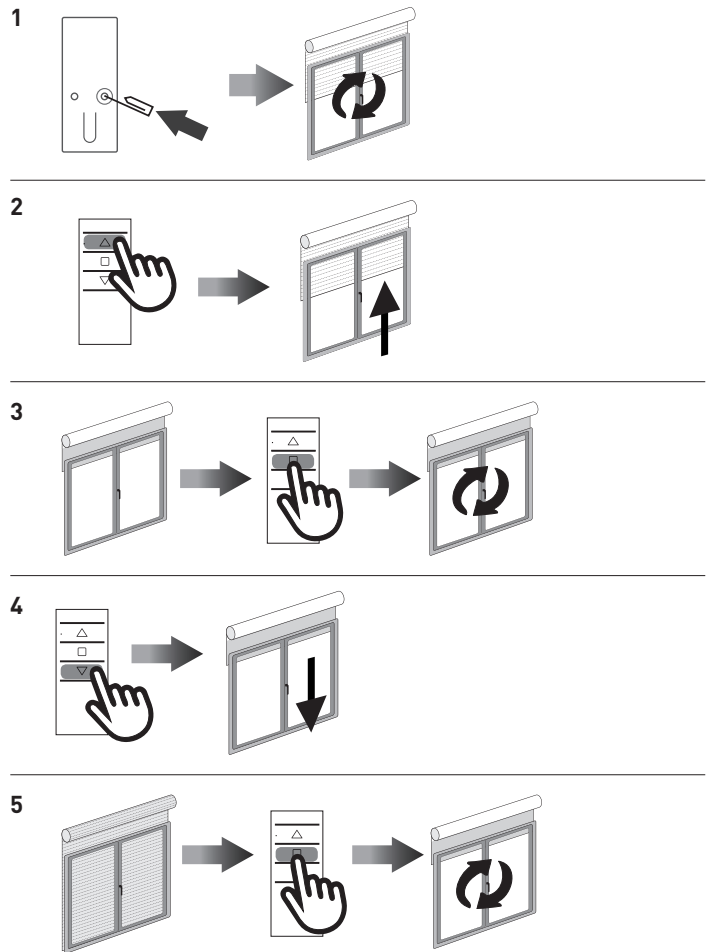

SETTING THE LIMITS INDIVIDUALLY (Sec. 5)

If the limits need to be changed after the initial limit setting procedure, it is possible to change the limit positions individually. One limit can be set without the other limit needing to be set. The motor can be in any position to initiate the procedure.

TO CHANGE THE UP LIMIT:

- 1 From any point between the existing limits, press and hold both the LIMIT button and the UP button until the motor makes a brief jog.

Note: during "limit setting mode" the operations are in "deadman control" (The UP and DOWN buttons must be held down in order to move the motor.)

- 2 Press and hold the UP button until the desired new UP limit is reached.
- 3 Press the STOP button to set the limit. The motor makes a brief jog to confirm. The new UP limit is set.

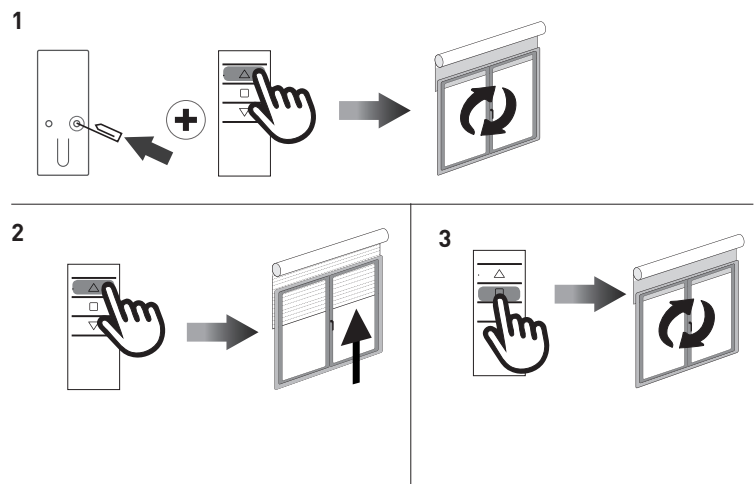

TO CHANGE THE DOWN LIMIT:

- 1 From any point between the existing limits, press and hold both the LIMIT button and the DOWN button until the motor makes a brief jog.

Note: during "limit setting mode" the operations are in "deadman control" (The UP and DOWN buttons must be held down in order to move the motor.)

- 2 Press and hold the DOWN button until the desired new DOWN limit is reached
- 3 Press the STOP button to set the limit. The motor makes a brief jog to confirm. The new DOWN limit is set.

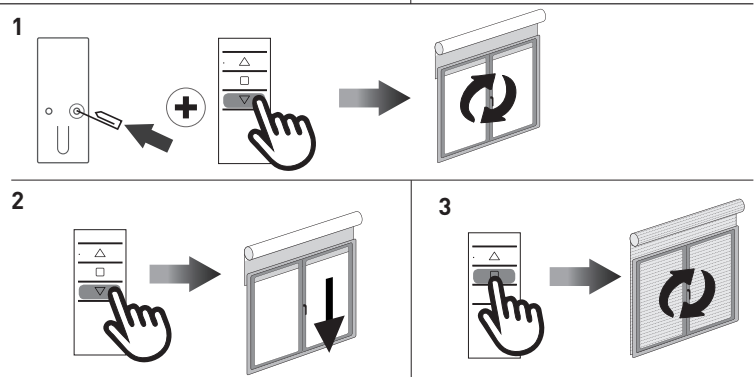

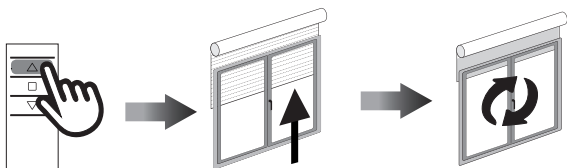

AUTOMATIC SETTING OF THE LIMITS (Sec. 6)

For limits set with torque sensor (mechanical stop of shutters or cassette awnings/shades), press and hold the UP button until the bottom bar hits the cassette or shutter box. A short jog will indicate that the UP position has been memorized. The same procedure can be followed for the DOWN limit but only for roller shutters.

PREFERRED POSITION (Sec. 7)

1. SETTING AN PREFERRED POSITION

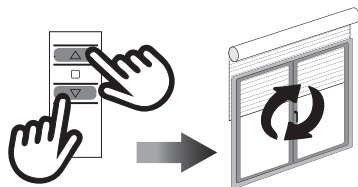

Operate the motor to and stop it at the desired intermediate position, then press both the UP and DOWN buttons together until the motor makes a brief jog to confirm.

The intermediate position is now set.

2. RECALLING THE PREFERRED POSITION

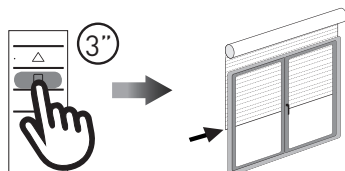

Press and hold the STOP button for 3 seconds: the motor will move to and stop at the intermediate position.

3. ERASING THE PREFERRED POSITION

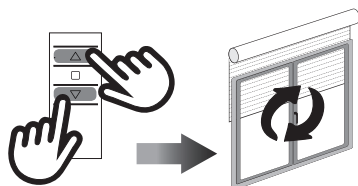

Press both the UP and DOWN buttons until the motor makes a brief jog to confirm.

The intermediate position is now erased.

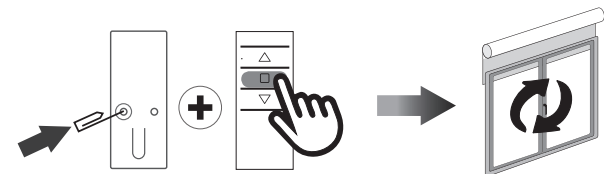

DELETING A TRANSMITTER OR A CHANNEL (Sec. 8)

Using the transmitter to be deleted press and hold both the SYNC and STOP buttons until the motor makes a brief jog to confirm.

Only the transmitter used for this procedure has been deleted from motor memory

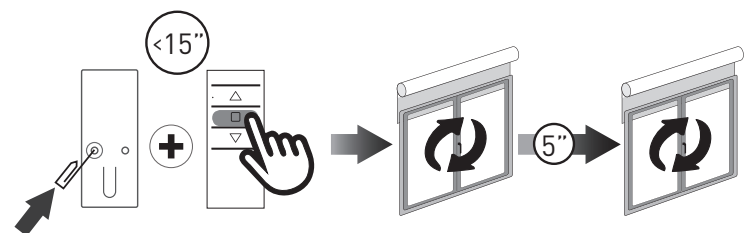

RESET TRANSMITTER MEMORY (Sec. 9) (DELETING ALL THE TRANSMITTERS OR CHANNELS OR SENSORS)

Option 1 - Using a programmed transmitter

Press and hold both the SYNC and STOP buttons for at least 15 seconds: to confirm that the operation has completed, the motor first makes a brief jog and after 5 seconds it makes an additional jog. This operation will not be successful unless it makes both jogs.

Memory is now empty

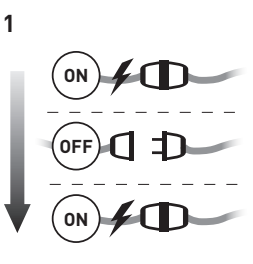

2

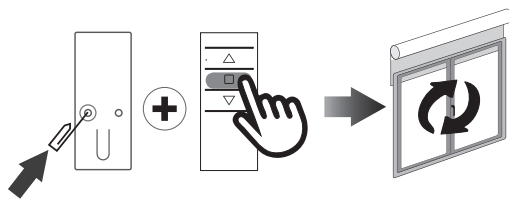

Option 2 - Using a new transmitter without ID (not paired).

1 Switch the power to the motor OFF, then switch it back ON.

2 Within 8 seconds, using any Gaposá transmitter, press and hold both the SYNC and STOP buttons until the motor makes a jog.

Memory is now empty

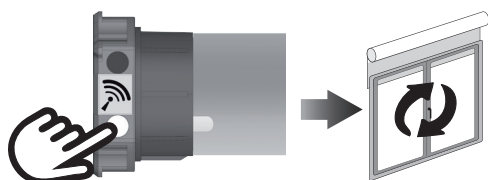

Option 3 - White button on the head of the motor

Press and hold the white button on the head of the motor until it makes a jog.

All transmitters have been erased.